



THE INTERDISCIPLINARY CENTER, HERZLIYA

EFI ARAZI SCHOOL OF COMPUTER SCIENCE

Accelerating Regular Expression Matching over Compressed HTTP Traffic

Submitted in Partial Fulfillment of the
Requirements for the Degree of Master of Science
(M.Sc.) Research Track in Computer Science

Submitted by Omer Kochba

Under the supervision of Prof. Anat Bremler-Barr
& Dr. Yaron Koral

March 2016

Abstract

This work focuses on regular expression matching over compressed traffic. The need for such matching arises from two independent trends. First, the volume and share of compressed HTTP traffic is constantly increasing. Second, due to their superior expressibility, current Deep Packet Inspection engines use regular expressions more and more frequently.

We present an algorithmic framework to accelerate such matching, taking advantage of information gathered when the traffic was initially compressed. HTTP compression is typically performed through the GZIP protocol, which uses back-references to repeated strings. Our algorithm is based on calculating (for every byte) the minimum number of (previous) bytes that can be part of a future regular expression matching. When inspecting a back-reference, only these bytes should be taken into account, thus enabling one to skip repeated strings almost entirely without missing a match. We show that our generic framework works with either NFA-based or DFA-based implementations and gains performance boosts of more than 70%. Moreover, it can be readily adapted to most existing regular expression matching algorithms, which usually are based either on NFA, DFA or combinations of the two. Finally, we discuss other applications in which calculating the number of relevant bytes becomes handy, even when the traffic is not compressed.

Contents

Abstract	i
Contents	ii
List of Figures	iv
List of Tables	v
1 Introduction	1
2 Background	4
2.1 Compressed HTTP	4
2.2 Deep Packet Inspection Algorithms	5
2.3 String Matching Over Compressed Traffic	6
3 Related Work	8
4 The ARCH Framework	10
4.1 Input-Depth Calculation for NFA-Based Implementations	12
4.2 Input-Depth Estimation for DFA-Based Implementations	14
4.2.1 Estimation based on Simple and Complex States	15
4.2.2 Estimation based on Positive and Negative Transitions	17
5 ARCH-DFA System Architecture	23
6 Experimental Results	25
6.1 Data Set	25
6.2 ARCH performance	26
7 Additional Applications	29
7.1 Extraction of a matched pattern	29
7.2 Patterns across packet fragmentation	30
7.3 Efficient Pre-Filtering	30
8 Conclusion	31

Bibliography

List of Figures

4.1	DFA Example	11
4.2	DFA Example	11
4.3	NFA Example	14
4.4	Basic automaton operators	17
4.5	DFA Example for positive/negative transitions	18
4.6	Data structures used for positive/negative transition marking	21
5.1	Illustration of the Hybrid ARCH-DFA System architecture	24
6.1	<i>Input-Depth</i> Cumulative Distribution	28

List of Tables

4.1	Simulation of ARCH over Active States NFA.	14
6.1	Rule-sets characteristics	25
6.2	ARCH Performance	26

List of Algorithms

1	Modified subset construction algorithm	19
2	Marking positive/negative transitions	20
3	ARCH-DFA Input-Depth Maintenance	21

Chapter 1

Introduction

Deep packet inspection (DPI) is a crucial component in many of today's networking applications, such as security, traffic shaping, and content filtering. It is considered a system performance bottleneck, since it inspects the packets' payload in addition to their header. Recently, especially due to the proliferation of mobile devices with limited bandwidth, DPI components have had to deal also with compressed traffic. This adds an additional performance penalty of data decompression prior to the inspection. Finding an efficient solution is crucial as nowadays *the majority of Web-sites use compression*.¹ HTTP compression is typically done with the GZIP protocol, which uses pointers to repeated strings within the traffic. Current literature focuses on DPI over compressed traffic for patterns that consist of strings. However, contemporary DPI engines are required to support also regular expressions.

This work aims at providing a *generic* solution to accelerate *any* regular expression matching on compressed traffic. As such, it applies to a wide range of methods for regular expression matching over plain-text (namely, uncompressed) traffic. The inspection is accelerated by avoiding scanning repeated strings within the input text (namely, the strings represented as pointers in GZIP), which were in a sense "already scanned". Extra care is taken to detect and handle delicate cases where the regular expression matches consecutive repeated and non-repeated strings (e.g., a pattern prefix followed

¹A recent report shows that 64.4% of the Internet Web sites use HTTP compression. When looking at the top 1000 most popular sites, over 92% of them use HTTP compression [1].

by a pointer to a repeated string). DPI algorithms rely mostly on finite automata. In case of string matching, every state within the automaton corresponds to a single string. Therefore, storing the information about the previously traversed states is sufficient to determine the amount of bytes of the input text that may be safely skipped when encountering a pointer within a compressed input (as discussed in Chapter 2). In case of regular expressions, every state may represent a wide set of strings with various lengths, as in the presence of the ‘*’ operator. For instance, given the pattern ‘ab+c’, the input strings ‘abc’ and ‘abbbbc’ cannot be distinguished based on the information of the automaton state alone as both input strings’ scans lead to the same state. To overcome this problem, we provide an algorithm that evaluates a new parameter called *Input-Depth*, which relates to the length of the input’s shortest suffix that leads to the current state from the automaton’s root.

We provide an algorithmic framework called *Acceleration of Regular expression matching over Compressed HTTP* (ARCH), which uses the *Input-Depth* parameter. We derive two system designs from this framework with respect to the two distinct DPI approaches, namely: **two phase inspection** — string based pre-filtering accompanied by an NFA scan for regular expression matching, and a **single pass inspection** — DFA-based regular expression matching. Our experiments show that the first design, denoted by ARCH-NFA, skips up to 79% of the inspected traffic and thus gains more than 4.8 times performance boost with respect to the second phase of regular expression matching. This design has a significant practical importance as it relates to the architecture used by the popular Snort IPS [2]. Our second system design, denoted by ARCH-DFA, also skips up to 79% of the inspected traffic and gains more than 3.4 times performance boost for moderate size pattern sets. Next we show how ARCH applies to large pattern sets that require a multi-DFA design to avoid state-space explosion. This design maintains almost the same average skip ratio of 78% and gains a performance boost of 3.3 times.

This work makes the following contributions:

1. A study of the challenges of regular expression matching over compressed traffic.
2. The first algorithmic framework that accelerates regular expression matching over compressed traffic.

-
3. A generic algorithm to accelerate regular expression matching over NFA based automata.
 4. A generic algorithm, with two variants, to accelerate regular expression matching over DFA based automata.
 5. A system setup which allows handling large, complex rule-sets which cause state-space explosion.
 6. A live setup which experiments both the correctness as well as the performance benefits of using the different algorithms.
 7. A discussion of additional possible applications for this algorithm.

Chapter 2

Background

2.1 Compressed HTTP

Compressed HTTP (namely, *content coding* for HTTP) is a standard method of HTTP 1.1 [3]. The standard describes the following content codings: GZIP, DEFLATE and COMPRESS. Practically, only the former two schemes are used. Since GZIP is a variant of DEFLATE, this work handles both algorithms in the same way. The GZIP algorithm [4] has two underlying compression techniques: LZ77 and Huffman coding.

1. **LZ77 compression** reduces data size by replacing repeated strings within the last 32KB of uncompressed data by a pointer with (distance, length) format, where *distance* indicates the distance in bytes of the repeated string from the current location and *length* indicates the number of bytes to copy from that point. For example the string: ‘abcdefabcx’ may be compressed to ‘abcdef(6,3)x’.
2. **Huffman coding** further reduces the data size by assigning variable-size code-words for *symbols*, thus enabling to encode frequent symbols with fewer bits.

GZIP compression first compresses the data using LZ77 compression and then encodes the literals and pointers using Huffman coding. Specifically, the algorithm in this work is based on the characteristics of the LZ77 compression.

2.2 Deep Packet Inspection Algorithms

DPI involves processing of the packet payload to identify occurrences of a set of pre-defined patterns. These patterns are expressed as either string or regular expressions. Early network IPSs relied solely on string matching, which is usually based on some variant of the Aho-Corasick [5] algorithm. This method uses a DFA to recognize multiple string signatures in a single pass and its running time is deterministic and linear in the input size.

Over the last years, security threats have become more sophisticated and required complex signatures, which can no longer be expressed as strings. Therefore, most security tools incorporate a regular expression matching engine. Regular expressions add three operators: concatenation (of two expressions), alternation (OR, ‘|’) and Kleene closure (‘*’ or ‘+’) and are defined recursively over them [6]. Such engines are typically implemented using either a DFA or an NFA.

DFAs scan the input in linear time, but use huge amount of memory due to the infamous state-space explosion problem. Approaches to tackle this problem include keeping cache of recently visited states [7], adding instructions to automaton edges [8], using edge compression techniques [9, 10], and using multiple DFAs [11] where only some are activated [12]. Our ARCH-DFA solution is based on A-DFA [10] and our design for large pattern sets is inspired by Hybrid-FA [12].

NFAs, on the other hand, use linear space but have worst-case quadratic time complexity [6], which may be exploited by an adversary for denial-of-service attack (DoS) on the DPI element itself [13, 14]. In NFAs, upon inspecting a symbol b in a current state s , one may need to transit to multiple next states (namely, by traversing all the outgoing edges of state s with label b). A common implementation maintains a set of *active states* S ; for each input byte b this set is recomputed by traversing all b -labeled edges from every state $s \in S$.

In practice, security tools with a large rule-set such as Snort [2], use a pre-filter based solutions. The pre-filter performs string matching on extracted strings from the regular expressions. When all strings of a specific rule match, a regular expression scan is

invoked using an NFA. The pre-filter can be accelerated over compressed traffic based on prior solutions for string matching (as described in the sequel), while the NFA part can be accelerated using our ARCH-NFA solution.

2.3 String Matching Over Compressed Traffic

LZ77 is an adaptive compression as each symbol is determined based on its preceding data. Therefore, there is no way to perform DPI without decompressing the data first [15]. Since decompression is a fairly inexpensive process, the real challenge is to *optimize the scanning of the decompressed data*. The idea behind the acceleration algorithm is to use the information gathered by the decompression phase to skip scanning significant parts of the data. An LZ77 pointer represents a repeated string that was already scanned. Therefore, it is possible to skip scanning most of it without missing any pattern. Still, tracking previous matches does not suffice due to cases where a pattern crosses a border of a repeated string. For example, given a pattern ‘`nbc`’ and an input string ‘`abcdnbn(7,5)c`’, while no match occurs at the repeated string ‘`bcdnb`’, there are matches occurring on both its left and right borders.

This problem is tackled by the DFA-based ACCH algorithm [15], *which is limited to string matching*. Upon encountering a repeated string it works as follows:

1. Scan the *left border* of the repeated string and update scan results.
2. Check whether the previous scan results of the repeated string contain matches.
3. Scan the *right border* of the repeated string and update scan results.
4. Update estimated scan results of skipped bytes within the repeated string.

In ACCH, scan results of previous bytes are stored in a 32K-entries *Status-Vector*. Its values are determined by $DFA-Depth(s)$ — the length of the shortest path from root to state s . There are three possible status values:

- MATCH: a pattern was matched (the match ends in the scanned byte).

- UNCHECK: $DFA-Depth(s)$ is below a threshold parameter $CDepth$ (in practice, $CDepth$ is set to 2).
- CHECK: otherwise.

ACCH uses the *Status-Vector* in the following manner:

Left Border Scan — Upon processing a repeated string, ACCH scans j bytes until reaching a state s where $j \geq DFA-Depth(s)$. From this point on, any pattern prefix is already included in the repeated string area. We refer to the first j bytes of the repeated string as the *left border* of the pointer.

Repeated Pattern Detection — This procedure examines the corresponding *Status-Vector* values of the referred string, starting at its $(j + 1)^{th}$ byte. If some byte at position m has a MATCH value, ACCH checks the length of that previously matched string. If it is m or more then the previously matched string was not repeated entirely. Otherwise, ACCH reports a matched pattern as in the referred string and marks that byte by a MATCH status.

Right Border Detection — ACCH determines the position to start inspection again such that no pattern (whose prefix is part of the repeated string suffix) is missed. This is done by estimating the $DFA-Depth$ of the repeated string's last byte (say this estimation is d) and scanning (from s_0) the last d bytes of the repeated string.

Update Status of Skipped Bytes — Skipped bytes cannot obtain their status from the scan procedure. Therefore, ACCH copies the status value for the skipped bytes from the corresponding referred string. Note that since ACCH skips only after it ensures that there is no pattern whose prefix started prior to the repeated string, the value of the estimated $DFA-Depth$ could be only equal or greater than its actual value (namely, setting a byte as CHECK while it should be UNCHECK). Such a mistake leads to minor reduction in the amount of skipped bytes but never to a miss-detection.

Chapter 3

Related Work

HTTP compression is a very popular method in the Internet. There are many works (e.g., [16–18]) that suggest acceleration of the compression method itself to support high request volume from high-end servers. These papers support the compression layer of the data without referring to the context of processing the data itself as in the case of DPI.

As noted in Chapter 2, HTTP compression uses LZ77 compression. There are various works in the literature regarding pattern matching methods over the Lempel-Ziv compression family [19–22]. However, the LZW/LZ78 variants are more attractive and simple for pattern matching than LZ77, thus all the above proposals are not applicable to our case. Klein and Shapira [23] suggested a modification to the LZ77 compression to simplify matching in files. However, their suggestion is not implemented in today’s Web traffic. Farach et. al [24] deal with pattern matching over LZ77. However, their proposed algorithm matches only a single pattern and requires two passes over the compressed text (file), which does not comply with the ‘on-the-fly’ processing requirement of network applications.

The ACCH algorithm [15], discussed in details in Chapter 2, was the first to tackle the problem of multi-pattern matching over compressed HTTP traffic. Following this work, another algorithm, named SPC [25], analyzes the usage of the Wu-Manber pattern matching algorithm [26] instead of the DFA-based Aho-Corasick[5] algorithm that lies at

the core of ACCH. SPC provides superior performance results over ACCH in the case of normal traffic while its worst-case performance is very poor. Note that there is no variant of the Wu-Manber algorithm that is applicable to regular expression matching, thus SPC cannot be used in our case. The SOP [27] algorithm minimizes the memory footprint required by the ACCH data structures. It may be combined with our algorithm, with few adaptations, to save space. Finally, Berger and Mortensen [28] provide a hardware scheme for the decompression phase, but do not deal with the scanning of the compressed data itself.

All the above mentioned works are limited to *string matching* rather than to devices based on regular-expression-matching. Sun et al. [29] suggested a method to perform regular expression matching over compressed HTTP. Still that method handles only simple cases, where the DFA is either at its root state or at a state with a direct transition from the root state. Practically, the DPI engine traverses to deeper DFA states. Furthermore, an attacker may easily craft an input that causes the DFA traversal into areas that the algorithm of Sun et al. fails to support. Robustness against such attacks is crucial as IDSs are a preferred target for denial-of-service attacks.

Chapter 4

The ARCH Framework

This chapter presents our framework: *Acceleration of Regular expression matching over Compressed HTTP* (ARCH). Conceptually, ARCH is based on the same ideas as the ACCH algorithm (as described at Chapter 2), which works only for string matching. One of the key insights used in ACCH is that the *DFA-Depth* of a state represents the longest suffix of the input that can still be part of a (future) match. This property holds for string matches and it greatly simplifies the design of ACCH, as it enables both left- and right-border resolution based solely on the state of the DFA.

Unfortunately, for regular expression matching this property does not hold since a state may represent an input of variable lengths. This happens as a result of an alternation between different-length expressions or a Kleene closure (namely, ‘*’ or ‘+’). An example of a state with an ambiguous depth in the presence of an alternation operator is depicted in Fig. 4.1, which represents an automaton accepting the pattern ‘(apple|pear)s’. The $DFA-Depth(s_5)$ value is 4 since it is the shortest path length from s_0 to s_5 . Therefore, in the case of an input byte sequence of: ‘zpplesxa(7,5)s’, the *DFA-Depth* after scanning the string ‘apple’ at the repeated string would be 4, while the minimal input suffix that should have been scanned to reach s_5 from root is 5. Wrong *DFA-Depth* may lead to miss-detection in ACCH.

An example of a state with an ambiguous depth in the presence of a Kleene closure is demonstrated in Fig. 4.2. The DFA is for ‘ab+c+’ and an input of ‘bbbbbbcxa{8,7}’

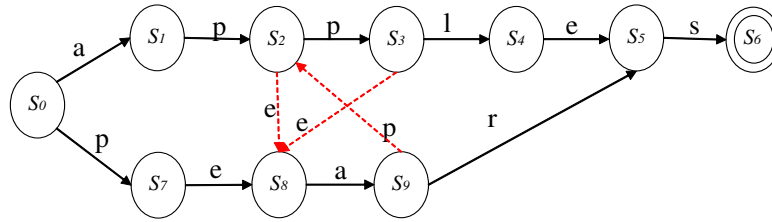

FIGURE 4.1: DFA for ‘(apple|pear)s’. Failure transitions are marked with red dashed arrows. Failure transitions to states with *DFA-Depths* 0 and 1 are omitted for clarity.

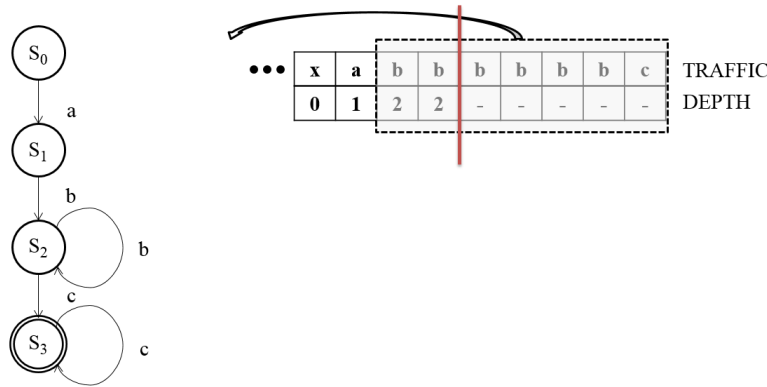

FIGURE 4.2: DFA for ‘ab+c+’. The right table indicates the input data and its *DFA-Depth* as derived from the automaton while scanning the input.

for which the repeated string is ‘bbbbbbc’. The repeated string scan starts at s_1 . After scanning two ‘b’ characters the automaton is still at s_2 , hence the *DFA-Depth*(s_2) does not change and is still 2. Thus, the left border detection of ACCH would have been completed at this point, skipping the rest of the repeated string and resuming the scan at the right border. This, of course, leads to a miss-detection, which is unacceptable.

Therefore, a key challenge behind ARCH is to calculate the minimum number of (previous) bytes that can be part of a future regular expression matching. This number is captured by the *Input-Depth* parameter, which is defined precisely below. It is important to notice that unlike ACCH’s *DFA-Depth*, *Input-Depth* depends both on the automaton state and the inspected input.

Definition 1. For a given automaton, let s_0 be the start state and s be the current state after scanning input text X with the automaton. Let *Input-Depth*(X, s) be the length of the shortest suffix of X in which inspection starting at s_0 ends at s .

We note that in the case of string matching, *Input-Depth* equals *DFA-Depth*. In fact,

the ARCH framework uses the ACCH algorithm to calculate possible scan skipping by replacing the *DFA-Depth* parameter with the *Input-Depth* parameter along with specific implementations for the different setups, as described in the sequel. Thus, if there is no match, the *Status-Vector* value CHECK is determined according to whether *Input-Depth* is greater than *CDepth* and, if not, the value is UNCHECK. The calculation of *Input-Depth* is done differently in NFA-based and DFA-based implementations, where in the former the value can be calculated precisely, while in the latter it can only be estimated. In the next sections, we will discuss these calculations and estimations as well as the correctness of the ARCH algorithm in detail.

4.1 Input-Depth Calculation for NFA-Based Implementations

Recall that one possibility to provide regular expression matching is to use NFAs, which are usually compact but slow data structures. We start our discussion with such implementations as they are simpler and help to grasp a better understanding of ARCH (DFA-based Implementations pose extra complications on top of ARCH and are discussed in Section 4.2). Moreover, NFAs are currently used by the popular Snort IPS, and therefore, accelerating their operations has a merit on its own. A commonly used NFA implementation which we refer to is *Active-States NFA*. This implementation maintains a set of active states. During each step, if there is a valid transition from an active state s to one or more states denoted by the set S' , then this state is replaced in the active-states set by the set S' . In this case we refer to s as the predecessor of each state in S' . If there are no such transitions, the state simply becomes inactive, i.e. removed from the active-states set.

ARCH maintains an *Input-Depth* value for each element in the active-states set. Namely, given an input prefix Y , an active state s , an input byte b , and a subsequent active state set S' such that there is a transition between s and each state s' in S' with a label b , the value of $Input-Depth(Yb, s')$ is set to $Input-Depth(Y, s) + 1$. The only exception is at

the start state of the NFA (which is always active) and for which $Input-Depth(Y, s_0)$ is always zero. Incrementing the $Input-Depth$ by 1 is based on the following claim:

Claim 1. The $Input-Depth$ of an active state can only grow by 1 compared to its predecessor.

Proof. Given an NFA, its active state set S , and an input byte T_{i+1} . For each state s' , that is a new state added to the active-states set, there exists at least one labeled transition from some state s which is already in the active states set, denoted by T_{i+1} . Assume on the contrary that $Input-Depth(T_{i+1}, s') > Input-Depth(T_i, s) + 1$. Thus inspecting a suffix of only T_{i+1} from the active state s would end up in a set of states S'' that does not include s' , in contrary to the assumption that T_{i+1} leads to s' . Therefore this is a contradiction, hence $Input-Depth$ grows at most by 1 compared to its predecessor after each step. \square

We define $A(Y)$ as the active-states set after scanning the input Y . We define the $Global-Input-Depth(Y)$ as the longest relevant suffix of the input. We determine $Global-Input-Depth(Y)$ by choosing the maximal $Input-Depth(Y, s)$ where s belongs to $A(Y)$. When ARCH needs to determine the left or right border of a pointer it uses the $Global-Input-Depth(Y)$. This is based on the following claim:

Claim 2. The $Global-Input-Depth(Y)$ is bound by the maximal $Input-Depth$ of the active states set.

Proof. Assume on the contrary that the $Global-Input-Depth(Y)$ denoted by x is larger than the maximal $Input-Depth$ of $A(Y)$ such that $x > \max(Input-Depth(Y, s) \mid s \in A(Y))$. Thus, for the current input, there is a suffix of length x that resulted in at least one state s' for which $Input-Depth(Y, s') = x$. Then, s' does not belong to $A(Y)$ because otherwise $x = \max(Input-Depth(Y, s) \mid s \in A(Y))$, contrary to the assumption that $x > \max(Input-Depth(Y, s) \mid s \in A(Y))$. Therefore this implies that the construction algorithm is incorrect, which contradicts the basic Thompson algorithm for pattern matching [30]. Therefore the global NFA $Input-Depth$ is bound by the maximal $Input-Depth$ of the active states set. \square

TABLE 4.1: Simulation of ARCH over Active States NFA.

Input Character	Active States	Input-Depth Set	Max Input-Depth
z	s_0, s_1, s_7	0, 1, 1	1
f	s_0, s_7, s_8	0, 2, 2	2
\n	s_0	0	0
z	s_0, s_1, s_7	0, 1, 1	1
a	s_0, s_2, s_7	0, 2, 2	2
b	s_0, s_3, s_7	0, 3, 3	3
c	s_0, s_4, s_7	0, 4, 4	4
f	s_0, s_5, s_7, s_8	0, 5, 5, 5	5
e	s_0, s_7, s_9	0, 6, 6	6

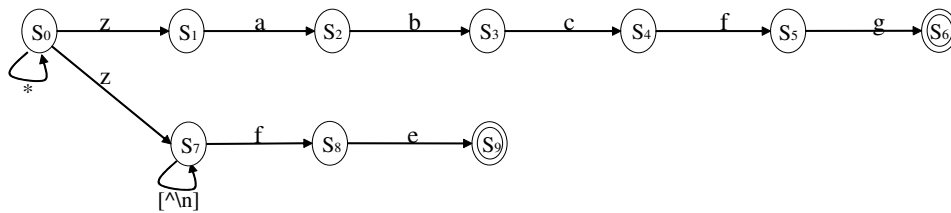
FIGURE 4.3: NFA of pattern set: ‘zabcfg’, ‘z^[^n]*fg’.

Since the *Input-Depth* of each active state can only increase by at most 1 (claim 1), the *Global-Input-Depth*(Y) of the NFA increases by at most 1 after inspection of a single byte.

Fig. 4.3 depicts an NFA for the patterns ‘zabcfg’ and ‘z^[^n]*fg’. The execution of ARCH for input ‘zf\nzabcfe’ and the NFA are illustrated in Table 4.1.

4.2 Input-Depth Estimation for DFA-Based Implementations

The task of *Input-Depth* calculation is more challenging when a DFA is used for regular expression matching. This is because, unlike NFA, a DFA transition may result either in increasing the *Input-Depth* (by one) or decreasing the *Input-Depth* (by any value). In this section, we provide an *upper bound* on the *Input-Depth* using two methods: by *simple and complex states* and by *positive and negative transitions*. As a rule, we use

the upper bound as the value of the *Input-Depth* in the ARCH framework. Thus, we take a conservative approach and never miss a match. Yet, the tighter the upper bound is, the higher the skip ratio we achieve.

4.2.1 Estimation based on Simple and Complex States

As noted above, *Input-Depth* cannot be always derived from *DFA-Depth*. Still, there are cases where we can derive it safely. In fact, we could split the DFA states into two kinds: those which represent a fixed string expression (where *Input-Depth* equals *DFA-Depth*) and those which represent a set of strings with various lengths. For instance, in the DFA of Fig. 4.2, states s_0 and s_1 are simple and states s_2 and s_3 are complex. More formally, this is captured in the following definition:

Definition 2. A *simple* state s is a state for which all possible input strings that upon scan from s_0 terminate at s have the same length. All other states are *complex*.

Given the above definition, the following claim holds for complex states:

Claim 3. If a state s is complex then there is at least one path, whose scan from s_0 terminates at s , where *Input-Depth* can be inflated (i.e. there are bytes or strings that can be added to the input text such that the *Input-Depth* will grow while the *DFA-Depth* remains the same).

Proof. Given a DFA and the current state s , which is complex. Assume on the contrary that a scan from s_0 which terminates at s cannot be inflated. Then there exists no transition along all possible paths from s_0 to s that may inflate the *Input-Depth*, i.e. increase the *Input-Depth* without increasing the *DFA-Depth*. However, by the definition of a complex state, s is only complex if it can be reached from some other complex state t which was marked complex because of a backward transition to the current path that may inflate the *Input-Depth*. Therefore, this is a contradiction and therefore there exists at least one path whose scan from s_0 terminates at s , where *Input-Depth* can be inflated. □

Input-Depth Estimation: According to claim 3 above, one cannot estimate *Input-Depth* of a complex state by the automaton properties solely, as the upper bound would always be infinity. To provide a better upper bound we estimate *Input-Depth* of complex states online per each scan step. Since per input character the *Input-Depth* can grow by at most 1 (as shown in claim 4 below), we estimate *Input-Depth* for complex states by incrementing it by 1. Therefore, *Input-Depth* estimation by simple and complex states works as follows: upon traversal to a simple state, *Input-Depth* is set to the *DFA-Depth* of the state; upon traversal to a complex state, *Input-Depth* is incremented by one. We note that by using this method *Input-Depth* may be over-estimated for complex state. However, this is corrected whenever the automaton falls back to a simple state where the *Input-Depth* is derived exactly.

Claim 4. Inspection of a single byte increases *Input-Depth* by at most 1.

Proof. Let the last two transitions of inspecting $T_{1..i+1}$ lead to states s and s' respectively. Assume on the contrary that $Input-Depth(Y, s') > Input-Depth(s) + 1$. Thus inspecting the input character of only T_{i+1} from state s would end up in a state $s'' \neq s'$. Thus for input byte T_{i+1} from state s there are two transitions to two different states s' and s'' , which is not possible in DFA. Therefore this is a contradiction, hence *Input-Depth* grows at most by 1 after each step. \square

Detection of Simple/Complex states: Our algorithm detects simple and complex states based on the DFA construction procedure as described by Thompson [30]. Thompson's construction has three significant stages: NFA construction from expressions, ϵ -transitions removal, and finally, DFA construction based on the resulting NFA. The basic idea of our algorithm is that we mark simple and complex states during NFA construction, and then we transfer these marks to the final DFA. The NFA construction is defined over the three basic regular expression operators as in Fig. 4.4. The operands are regular expressions R and S . All states are marked as *simple* by default and stay that way unless otherwise specified. Complex states are marked according to each regular expression operator as follows:

- **Kleene Closure** (Fig. 4.4(a)): Mark all states as complex.

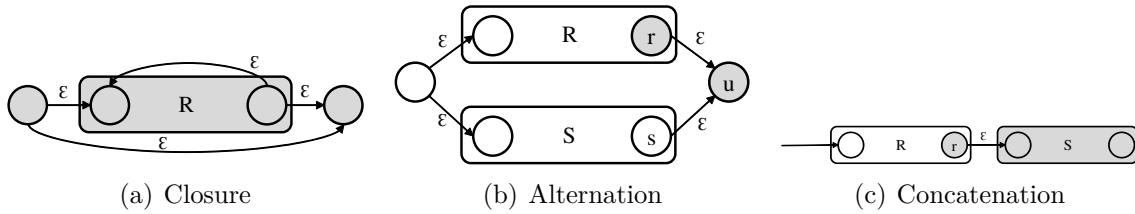

FIGURE 4.4: The basic operators considered in Thompson's construction [30].

- **Alternation** (Fig. 4.4(b)): If either states r or s are complex, mark state u as complex.
- **Concatenation** (Fig. 4.4(c)): If state r is complex, mark all states of S as complex.

The simple/complex state marks are transferred through the Thompson construction stage to the final DFA as follows: the ϵ -transition (a transition that is used in non-deterministic automata for minimization purposes, which allows an automaton to change its state without consuming an input symbol) removal stage only removes redundant transitions and states, therefore, all remaining states are still marked. Next, the NFA is transformed into a DFA using the *subset-construction method*, which traverses the entire NFA and creates a DFA state for each possible set of active states. This DFA state is marked simple if and only if all of the corresponding active NFA states are simple.

4.2.2 Estimation based on Positive and Negative Transitions

In the previous section we estimated an upper bound for *Input-Depth* using simple and complex states. Although the method is intuitive and efficient, it may overestimate *Input-Depth* in some cases, thus causing redundant scans. In this section we provide a method to estimate a more accurate upper bound on the value of *Input-Depth*. It is based on transitions rather than on states.

The positive and negative transition technique relies on the observation that *Input-Depth* depends on the *transition between two states* rather than only the state in its endpoint. For example, Fig. 4.5 shows that the transition from s_x to s_y should increase the *Input-Depth*, the transition between s_z to s_y should leave the *Input-Depth* unchanged, and the

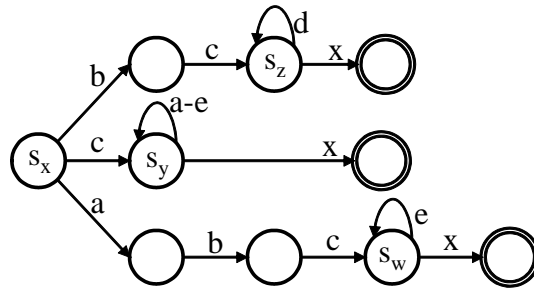

FIGURE 4.5: DFA for pattern set $\{c[a-e]^*x, bcd^*x, abce^*x\}$.

transition between s_w to s_y should decrease the *Input-Depth* by 1. This implies that the *Input-Depth* calculation cannot solely depend on s_y .

Thus, we define two types of transitions: A *positive-transition*, which increases *Input-Depth* by one (e.g. a byte was added to the pattern's prefix) and *negative-transition*, which either decreases or leaves *Input-Depth* unchanged. The challenge is to detect negative-transitions and determine the exact change they apply on the *Input-Depth* value.

Negative-transition detection is performed in two stages. In the first stage, for each state we calculate a *candidate label*, denoted by $c\text{-label}(s)$, which helps detecting negative transitions in the second stage. Let $L(s)$ be the set of all input strings that are accepted by s . We choose $c\text{-label}(s) \in L(s)$ such that $c\text{-label}(s).length \leq l(s).length$ for any $l(s) \in L(s)$. The algorithm is depicted in Alg. 1. We refer to the second stage of the Thompson construction (as described at Section 4.2.1), which is the subset-construction that constructs a DFA from an NFA. The $c\text{-label}(s)$ parameter is determined by integrating a line into the subset-construction algorithm (as in Alg. 1 Line 8). The algorithm uses the following basic NFA operations:

- $\epsilon\text{-closure}(T)$ — The set of NFA states reachable from each NFA state s in set T on ϵ -transitions alone.
- $\text{move}(T,a)$ — The set of NFA states to which there is a transition on input symbol a from some state s in T .

Basically, the subset-construction algorithm traverses all NFA active state sets (Line 1) using all possible input symbols (Line 3) in a breadth-first search (BFS) manner. Each

unique NFA active set T results in a corresponding DFA state t (Line 7). When a transition from the DFA state t results in a DFA state u , which was never visited before, the algorithm creates a $c\text{-label}(u)$ by concatenating $c\text{-label}(t)$ and the transition label a (Line 8). Note that there may be more transitions that lead to DFA state u along the construction. Still, since BFS is used for the NFA traversal, and the $c\text{-label}(u)$ was generated upon the first transition that reaches u , $c\text{-label}(u)$ must be no longer than any other label in $L(u)$, as required.

<p>Data: Dstates, Dtrans — containers for DFA states and transitions respectively. Initially, $\epsilon\text{-closure}(\{s_0\})$ is the only state in Dstates and it is unmarked.</p> <pre> 1 while there is an unmarked state t in Dstates do 2 mark t; 3 foreach input symbol a do 4 $U = \epsilon\text{-closure}(\text{move}(t, a))$; 5 foreach state u in U do 6 if u is not in Dstates then 7 add u as an unmarked state to Dstates; 8 set $c\text{-label}(u) = c\text{-label}(t) \oplus a$; 9 end 10 Dtran[t, a] = u; 11 end 12 end 13 end </pre>

Algorithm 1: Modified subset construction algorithm. The symbol \oplus means concatenation.

At the second stage, for each state $t \in Dstates$ we iterate over all its transitions and determine whether they are negative or positive. For that we define a structure called *Anchored-NFA*, which is the NFA constructed from all regular expressions from the related DFA after they were *anchored*; namely, after they were restricted to be matched from the beginning of the input (represented by the ‘ \wedge ’ operator in the PCRE [31] package). Each transition (t, u) with label a is inspected as follows: the algorithm traverses the Anchored-NFA using $c\text{-label}(t)$ and receives an output of an active states set R in the Anchored-NFA (Line 2). If there exist an iteration with label a from R , then transition (t, u) is positive (Lines 4–6). The rest of the transitions are marked as negative. The intuition behind this algorithm is that a negative transition from t to u with label a applies that there is a suffix of $c\text{-label}(t) \oplus a$ that leads from the root to u . Therefore, a string such as $c\text{-label}(t) \oplus a$ cannot be accepted by the Anchored-NFA,

rather only its suffix. Thus, lack of transition at the Anchored-NFA applies a negative transition at the DFA. This procedure is possible due to the following claim:

Claim 5. For every $c\text{-label}(t)$ there exists a non-empty set of states R in the Anchored-NFA where $R = \epsilon\text{-closure}(\text{move}(c\text{-label}(t)))$.

Proof. Given a DFA, and its set of states S . For every state s in S there is a $c\text{-label}$ value denoted by $c\text{-label}(s)$. Assume on the contrary that there exists a state in the DFA t , its $c\text{-label}$ value is $c\text{-label}(t)$, and that the set of states $R = \epsilon\text{-closure}(\text{move}(c\text{-label}(t)))$ is empty. By definition, $c\text{-label}$ is set during the subset-construction algorithm by traversing the NFA in breadth-first search (BFS). If the state t was marked with $c\text{-label}(t)$, then there exists some state u in the NFA which corresponds to it. Since state u was reached by an input of the series of bytes that is equal to $c\text{-label}(t)$ then when simulating the same byte sequence on the corresponding Anchored-NFA, R cannot be empty because the Anchored-NFA is equivalent to the original NFA for patterns that exist in the beginning of the input (as in this case). Therefore this is a contradiction, and for every $c\text{-label}(t)$ there exists a non-empty set of states R in the Anchored-NFA where $R = \epsilon\text{-closure}(\text{move}(c\text{-label}(t)))$. \square

```

1 foreach state  $t$  in  $Dstates$  do
2    $R = \text{Anchored-NFA}(\text{move}(c\text{-label}(t)))$ ;
3   foreach input symbol  $a$  do
4      $u = Dtran[t, a]$ ;
5     if  $\epsilon\text{-closure}(\text{move}(R, a)) \neq \emptyset$  then
6        $Dtran[t, a].\text{positive} = \text{true}$ ;
7     else
8        $Dtran[t, a].\text{positive} = \text{false}$ ;
9     end
10  end
11 end

```

Algorithm 2: Marking positive/negative transitions

For example, consider the patterns ‘ $ab+c+d$ ’ and ‘ $bc+e$ ’. The resulting DFA from our modified subset construction is depicted in Fig. 4.6(a) and its full-matrix representation along with its calculated $c\text{-label}(s)$ values is depicted at Fig. 4.6(c). After running Alg. 2 using the DFA and the Anchored-NFA (depicted in Fig. 4.6(b)) all negative,

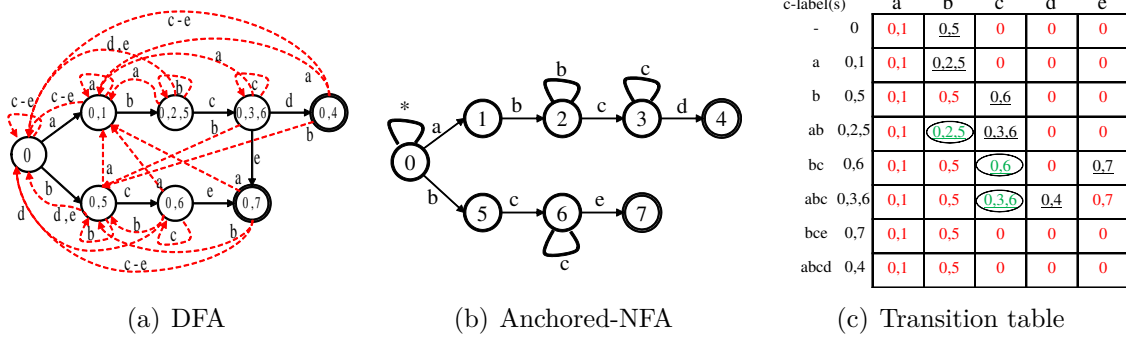

FIGURE 4.6: Data structures used for the positive/negative transition marking for pattern set: $\{\text{'ab+c+d'}, \text{'bc+e'}\}$.

positive (underline) and loop (circled) transitions are marked. All negative transitions are marked with dashed red arrows at Fig. 4.6(a). Note that the algorithm distinguishes between the “self-loop” of states $\{0\}$, $\{0,1\}$ and $\{0,5\}$ as a negative transition and the “self-loop” of states $\{0,2,5\}$, $\{0,3,6\}$ and $\{0,6\}$, which are marked positive. This is the desired outcome as in the former case *Input-Depth* should not increase upon loop traversal, while in the latter it should.

```

1 U=Dtran[T,a];
2 if Dtran[T,a] is positive then
3   | Input-Depth++;
4 else
5   | if U is simple then
6     | Input-Depth=U.DFA – Depth;
7   | else
8     | Decrease=c-label(T).len – c-label(U).len;
9     | Input-Depth=Input-Depth – Decrease;
10  | end
11 end

```

Algorithm 3: ARCH-DFA Input-Depth Maintenance

At this point, each transition at the DFA is marked as either positive or negative. The next step would be to determine the *Input-Depth* upon DFA traversal as described in Alg. 3. The straightforward case is upon a traversal over a positive transitions, for which the *Input-Depth* is incremented by one (Line 3). To handle negative transitions we use the classification of simple and complex DFA states as explained at the previous subsection. If a negative transition leads to a simple state, the *Input-Depth* is set to this

state's *DFA-Depth* (Line 6). Upon a negative transition to a complex state the *Input-Depth* should be decremented by the delta between the labels' lengths as described at Lines 8–9. We note that this algorithm does not support some corner cases (e.g., when a regular expression contains multiple loops and has a negative transition to another regular expression that contains only some of these loops), thus our algorithm just increments *Input-Depth* by one as it is its the maximal possible value. For that matter ARCH always provides an upper bound on the value of *Input-Depth*, and therefore, never misses a match.

Chapter 5

ARCH-DFA System Architecture

Observe that the problematic case of ARCH is where the algorithm cannot skip any bytes. This case may happen upon a closure operator over a wide range of characters (such as `.*`), which causes its descendant states to be complex and have only positive transitions, hence the *Input-Depth* never decreases. For instance, consider the pattern `AdminServlet.*(userid|adminurl)` (which was extracted from Snort’s rule set); after matching the prefix `AdminServlet`, *Input-Depth* cannot decrease since any character can be part of the pattern and may be followed by either `userid` or `adminurl`. Thus, ARCH cannot skip scanning characters in such cases as it never finds the *left border* of a pointer (see Chapter 4). This implies that whenever a closure operator acts upon a wide range of characters, the effectiveness of ARCH reduces. In some cases, the benefit of ARCH becomes smaller than its overhead. In such cases we would like to just run a regular DFA rather than ARCH-DFA to avoid the ARCH-DFA overhead, which is approximately 11% (see details in Chapter 6) due to additional memory accesses to the status-vector. We note that only 8.1% of the rules in the set that was derived from Snort and fits compressed Web traffic (i.e. Web traffic from server to client) contains `.*` expressions. A more frequent wide-range Kleene closure is of the form `[^\n]*`. Still, since we deal with HTML data, the new-line occurs on average after 75 characters, and therefore, the automaton “escapes” the above-mentioned case of only positive transitions, and therefore, does not harm much the ARCH performance, as described in Chapter 6. Additionally, when *Input-Depth* increases along scanning, ARCH never

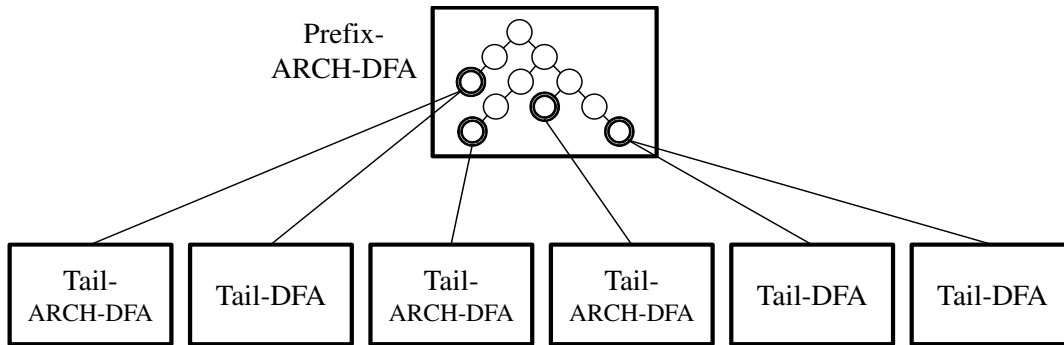

FIGURE 5.1: Illustration of the Hybrid ARCH-DFA System architecture

detects a pointer's *left border*, implying status vector checkups are redundant. We note that nowadays, the incurred overhead in the above-mentioned case is practically negligible, however, future pattern sets or implementations might be different.

ARCH is inspired by the design of Hybrid-FA by Becchi et al. [12]. ARCH system breaks the regular expressions into a prefix set of all expressions, which are represented by a single *prefix ARCH-DFA* (which is analogous to the head-DFA in [12]), and a set of *tail ARCH-DFAs* that represent the entire regular expressions set. The *prefix ARCH-DFA* is always active, while only a small part of the *tail ARCH-DFAs* may be active. This way the resulting hybrid automaton has a small memory footprint as compared to the corresponding DFA, with the penalty of traversing several automata in parallel. Using the above-mentioned architecture leaves us the freedom to decide in advance whether to use a *tail ARCH-DFA* or a *tail DFA* in the case where the overhead of ARCH is higher than its benefits as depicted in Fig. 5.1.

Chapter 6

Experimental Results

We evaluate the performance benefits of ARCH on rule-sets from the Snort IPS. The Snort24, Snort31, and Snort34 rule-sets were taken from [32]. The Snort135 rule-set was extracted from Snort's "*web-client.rules*" (February 2014). These rules relate to Web traffic. Table 6.1 summarizes the basic characteristics of the rule-sets used in the experiments.

6.1 Data Set

The data set contains 2301 compressed HTML pages, downloaded from 500 popular sites taken from the *Alexa* Web-site [33]. The data size is 358MB in uncompressed form and 61.2MB in compressed form. Since the algorithm is based on repeated byte sequences, it may only perform as well as the compression ratio of the input data and is therefore mainly aimed at highly-compressible inputs such as text.

TABLE 6.1: Rule-sets characteristics

Rule Set	Snort24	Snort31	Snort34	Snort135
Number of Rules	24	31	34	135
% Rules with Kleene Closure	37.5	41.9	38.2	89.6
% Rules with Char Ranges ≥ 50	50	48.4	41.1	51.9

6.2 ARCH performance

We compare ARCH with a baseline algorithm, which uses the same underlying automaton scheme (NFA or DFA) without performing any byte skipping. We define R_s as the scanned character skip ratio — the ratio of characters skipped using ARCH out of the total size of the input data. We define R_t as the saved scan time ratio — ARCH’s running time compared to the baseline algorithm’s running time.

ARCH-NFA was implemented using *active states NFA* as its baseline algorithm, as described in Section 4.1. Table 6.2 shows statistics regarding its performance. The average skip rate R_s is 77.99%, which results in a significant performance improvement R_t of 77.21%. Compared to the overall performance, the overhead of ARCH-NFA is less than 1%. The overall processing time of ARCH-NFA is relatively long compared to the DFA based implementations (40 times longer) and is therefore less preferred. On the other hand, the space requirements of ARCH-NFA are 18 times lower than those of ARCH-DFA. The Snort135 rule-set was not tested with ARCH-NFA due to the high memory requirements of representing many rules in a single automaton. This work does not aim to solve the low performance of NFA based algorithms, instead it aims to show that the ARCH algorithm fits and may be used by both approaches.

ARCH-DFA was implemented using *A-DFA* [10] as its baseline compression algorithm. The implementation performs *Input-Depth* estimation based on both of the methods described in Section 4.2. The results shown below are based on the simple and complex states method which is described in Section 4.2.1. This estimation has a lower overhead while the benefit gained by the more precise estimation of the positive/negative

TABLE 6.2: ARCH Performance

	Rule Set	Snort24	Snort31	Snort34	Snort135
NFA	Characters Skipped	79.44%	75.86%	78.66%	-
	Time Saved	79.29%	74.56%	77.78%	-
DFA	Setup	Single	Single	Single	Hybrid
	Characters Skipped	79.04%	75.64%	78.38%	78.46%
	Time Saved	70.97%	67.46%	69.14%	70.08%
	Number of Matches	168603	1333	8000	77801
	Run-time NFA/DFA	38.46	45.45	40	-

transitions method is not significant on our data sets. However, in order to prove the theoretical advantage of the positive/negative transitions method for certain edge cases, we created a synthetic data set which includes these edge cases. The result shows an improvement of approximately 18% in the average *Input-Depth* which allows the ARCH algorithm to skip more bytes and reduce the scan time.

We implemented two system setups for ARCH-DFA. The first uses a single *DFA* for the entire rule-set and is therefore useful for pattern sets with moderate size, which do not exhibit state explosion. Table 6.2 shows statistics regarding the performance of ARCH-DFA. ARCH-DFA achieved an average skip rate R_s of 77.69% and a performance boost R_t of 69.19%. In this case the overhead is more notable and is almost 11%. As discussed in Chapter 5, this is mainly due to additional memory references to the *Status-Vector* as compared to the baseline algorithm.

The second setup uses a hybrid design consisting of a prefix ARCH-DFA, which encodes the prefixes of the pattern set, and multiple tail ARCH-DFAs as described in Chapter 5. This setup is useful for pattern sets with considerable size and high complexity, which cause state-space explosion (e.g. Snort135). The average skip ratio R_s is 77.88% while the average gained performance boost R_t is 69.41%. The overhead in this case is also 11%. We note that since the performance improvement of the algorithm depends on the properties of both the input string and the regular expressions in the pattern set, the method may offer a lower performance gain when detecting patterns that contain a short string prefix followed by Kleen Closure.

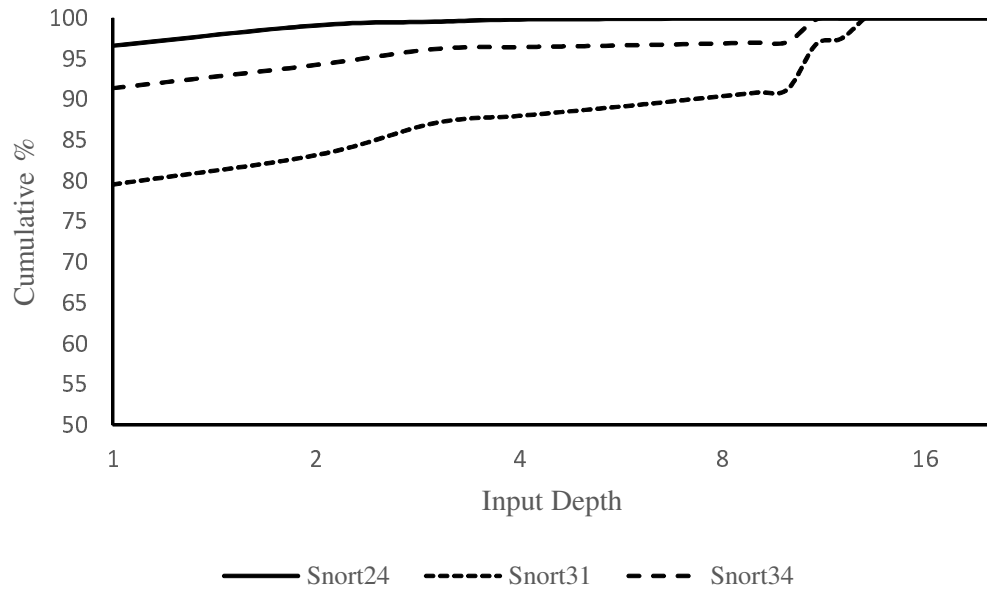

(a) NFA

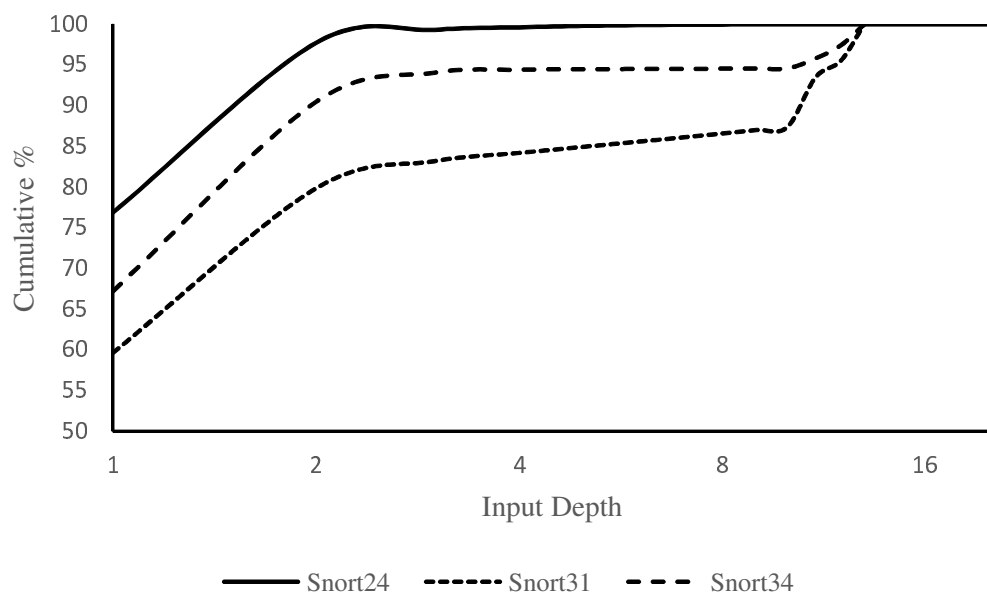

(b) DFA

FIGURE 6.1: *Input-Depth* Cumulative Distribution

Chapter 7

Additional Applications

Beside regular expression matching over compressed traffic, *Input-Depth* is important for many additional applications. In this chapter we describe three such applications:

1. Extraction of a matched pattern
2. Patterns across packet fragmentation
3. Efficient Pre-Filtering

7.1 Extraction of a matched pattern

A surprising fact is that there is no straightforward method to extract the string that relates to a matched pattern after detecting a match in the automaton (by reaching a matching state) without having to rescan the packet. The only information about the input that is available at this point is the position in the input in which the match occurred. *Input-Depth* allows this functionality as it indicates the number of bytes that should be extracted from the input up to the match position.

7.2 Patterns across packet fragmentation

Studies [34] have shown that Intrusion Prevention Systems may be evaded by using packet fragmentation. Such attacks are implemented by splitting the malicious pattern across several packets. A naive approach to handle such threats is to completely re-assemble the packets into one stream. This method may require high memory usage and severely impact performance in case of long matches across several packets. Therefore, an important related application may be to determine the number of bytes that should be stored to handle cross-packet DPI. Instead of buffering entire packets, a DPI engine may just store a matched pattern-prefix at each packet's suffix.

7.3 Efficient Pre-Filtering

Another important application is efficient pre-filtering for intrusion prevention systems. Systems such as Snort perform pre-filtering on a simpler automaton in order to identify the existence of a prefix of a pattern in the current packet. If the pre-filtering identifies such a match, the entire packet is re-scanned against the relevant regular expressions. Instead, an efficient pre-filtering method may use *Input-Depth* in order to scan only the relevant bytes in the second phase instead of having to re-scan the entire packet. This has an even larger benefit in the case where the match spans across several packets.

Chapter 8

Conclusion

ARCH started as an effort to adapt prior art of string matching over compressed traffic to the regular expression matching domain. Along this process we uncovered a wide set of complexities of both algorithmic and architectural aspects that the new domain holds. We aimed at providing a generic method that fits a wide range of solutions, therefore we analyzed both NFA and DFA setups and aimed at either moderate simple pattern sets and large complex ones. Three architectures are proposed: ARCH-NFA, ARCH-DFA and the Hybrid-ARCH-DFA.

This work not only provides the theoretical background behind the different methods, it also provides a setup that tests the performance benefits of the provided algorithms on real life Web traffic.

An important product of this research is the discovery of the *Input-Depth* parameter. Beside the fact that it is a crucial construct for regular expression matching over compressed traffic, we found that there are many other applications for which it is important.

Bibliography

- [1] W3Tech. Usage of Compression for websites, 2014. <http://w3techs.com/technologies/details/ce-compression/all/all>.
- [2] SNORT. Snort: The Open Source Network Intrusion Detection System. <http://www.snort.org>.
- [3] HyperText Transfer Protocol – [http]/1.1, June 1999. [RFC] 2616, <http://www.ietf.org/rfc/rfc2616.txt>.
- [4] P. Deutsch. Gzip file format specification, May 1996. RFC 1952, <http://www.ietf.org/rfc/rfc1952.txt>.
- [5] Alfred V. Aho and Margaret J. Corasick. Efficient string matching: an aid to bibliographic search. *Commun. ACM*, 18:333–340, June 1975. ISSN 0001-0782. doi: <http://doi.acm.org/10.1145/360825.360855>. URL <http://doi.acm.org/10.1145/360825.360855>.
- [6] John E. Hopcroft, Rajeev Motwani, and Jeffrey D. Ullman. *Introduction to Automata Theory, Languages, and Computation*. Pearson/Addison Wesley, 3rd edition, 2007.
- [7] Robin Sommer and Vern Paxson. Enhancing byte-level network intrusion detection signatures with context. In *CCS*, pages 262–271, 2003.
- [8] R. Smith, C. Estan, and S. Jha. Xfa: Faster signature matching with extended automata. In *Security and Privacy, 2008. SP 2008. IEEE Symposium on*, pages 187–201, May 2008. doi: 10.1109/SP.2008.14.

-
- [9] Sailesh Kumar, Sarang Dharmapurikar, Fang Yu, Patrick Crowley, and Jonathan Turner. Algorithms to accelerate multiple regular expressions matching for deep packet inspection. In *Proceedings of the 2006 conference on Applications, technologies, architectures, and protocols for computer communications*, pages 339–350, 2006.
- [10] Michela Becchi and Patrick Crowley. An improved algorithm to accelerate regular expression evaluation. In *ACM/IEEE ANCS*, pages 145–154, 2007.
- [11] Fang Yu, Zhifeng Chen, Yanlei Diao, T. V. Lakshman, and Randy H. Katz. Fast and memory-efficient regular expression matching for deep packet inspection. In *Proceedings of the 2006 ACM/IEEE symposium on Architecture for networking and communications systems*, pages 93–102, 2006.
- [12] Michela Becchi and Patrick Crowley. A hybrid finite automaton for practical deep packet inspection. In *ACM CoNEXT*, pages 1:1–1:12, December 2007.
- [13] Yehuda Afek, Anat Bremler-Barr, Yotam Harchol, David Hay, and Yaron Koral. Mca2: Multi-core architecture for mitigating complexity attacks. In *Proceedings of the Eighth ACM/IEEE Symposium on Architectures for Networking and Communications Systems*, ANCS '12, pages 235–246, New York, NY, USA, 2012. ACM. ISBN 978-1-4503-1685-9. doi: 10.1145/2396556.2396603. URL <http://doi.acm.org/10.1145/2396556.2396603>.
- [14] R. Smith, C. Estan, and S. Jha. Backtracking algorithmic complexity attacks against a nids. In *Computer Security Applications Conference, 2006. ACSAC '06. 22nd Annual*, pages 89–98, Dec 2006. doi: 10.1109/ACSAC.2006.17.
- [15] Anat Bremler-Barr and Yaron Koral. Accelerating multipattern matching on compressed http traffic. *IEEE/ACM Trans. Netw.*, 20(3):970–983, 2012.
- [16] P. Rauschert, Y. Klimets, J. Velten, and A Kummert. Very fast gzip compression by means of content addressable memories. In *TENCON 2004. 2004 IEEE Region 10 Conference*, volume D, pages 391–394 Vol. 4, Nov 2004. doi: 10.1109/TENCON.2004.1414952.

-
- [17] J.G. Franklin. Hardware accelerated compression, May 23 2006. URL <http://www.google.com/patents/US7051126>. US Patent 7,051,126.
- [18] K. Ma and W.W.W. Chen. Method and apparatus for efficient hardware based deflate, December 11 2007. URL <http://www.google.com/patents/US7307552>. US Patent 7,307,552.
- [19] A. Amir, G. Benson, and M. Farach. Let sleeping files lie: Pattern matching in z-compressed files. *Journal of Computer and System Sciences*, pages 299–307, 1996.
- [20] T. Kida, M. Takeda, A. Shinohara, and S. Arikawa. Shift-and approach to pattern matching in lzw compressed text. In *10th Annual Symposium on Combinatorial Pattern Matching (CPM 99)*, 1999.
- [21] G. Navarro and M. Raffinot. A general practical approach to pattern matching over ziv-lempel compressed text. In *10th Annual Symposium on Combinatorial Pattern Matching (CPM 99)*, 1999.
- [22] G. Navarro and J. Tarhio. Boyer-moore string matching over ziv-lempel compressed text. In *Proceedings of the 11th Annual Symposium on Combinatorial Pattern Matching*, pages 166 – 180, 2000.
- [23] ST. Klein and D. Shapira. A new compression method for compressed matching. In *Proceedings of data compression conference DCC-2000, Snowbird, Utah*, pages 400–409, 2000.
- [24] M. Farach and M. Thorup. String matching in lempel-ziv compressed strings. In *27th annual ACM symposium on the theory of computing*, pages 703–712, 1995.
- [25] Anat Bremler-Barr, Yaron Koral, and Victor Zigdon. Shift-based pattern matching for compressed web traffic. In *HPSR*, pages 222–229. IEEE, 2011. URL <http://dblp.uni-trier.de/db/conf/hpsr/hpsr2011.html#Bremler-BarrKZ11>.
- [26] S. Wu and U. Manber. A fast algorithm for multi-pattern searching. Technical Report TR-94-17, Department of Computer Science, University of Arizona, May 1994.

-
- [27] Yehuda Afek, Anat Bremler-Barr, and Yaron Koral. Space efficient deep packet inspection of compressed web traffic. *Comput. Commun.*, 35(7):810–819, April 2012. ISSN 0140-3664. doi: 10.1016/j.comcom.2012.01.017. URL <http://dx.doi.org/10.1016/j.comcom.2012.01.017>.
- [28] M.S. Berger and B.B. Mortensen. Fast pattern matching in compressed data packages. In *GLOBECOM Workshops (GC Wkshps), 2010 IEEE*, pages 1591–1595, Dec 2010. doi: 10.1109/GLOCOMW.2010.5700208.
- [29] Yan Sun and Min Sik Kim. Dfa-based regular expression matching on compressed traffic. In *Communications (ICC), 2011 IEEE International Conference on*, pages 1–5, June 2011. doi: 10.1109/icc.2011.5962596.
- [30] Ken Thompson. Programming techniques: Regular expression search algorithm. *Commun. ACM*, 11(6):419–422, June 1968. ISSN 0001-0782. doi: 10.1145/363347.363387. URL <http://doi.acm.org/10.1145/363347.363387>.
- [31] PCRE. PCRE - perl compatible regular expressions. <http://www.pcre.org>.
- [32] Michela Becchi. Regular expression processor. <http://regex.wustl.edu>.
- [33] Alexa. Alexa: The web information company, Dec 2011. <http://www.alexa.com/topsites>.
- [34] T. Ptacek and T. Newsham. Insertion, evasion and denial of service: Eluding network intrusion detection. *Secure Networks, Inc.*, Jan 1998.

תקציר

עבודה זו עוסקת בזיהוי תבניות בתעבורת HTTP דחוסה בעזרת ביטויים רגולריים. זיהוי מסוג זה נחוץ משתי סיבות עיקריות. תחילה, אחוז התעבורה הדחוסה ברשת, ובמיוחד באתרי אינטרנט, נמצא במגמת עליה מתמדת על מנת לצמצם את גודל התעבורה. שנית, מכיוון שמנועי סריקה אשר סורקים את תוכן המידע ברשת לצרכים שונים, ובמיוחד למטרות אבטחה, משתמשים כדרך קבע בביטויים רגולריים בגלל היכולת שלהם לבטא מספר גדול של תבניות בצורה פשוטה.

אנחנו מציגים בעבודה זו תשתית אלגוריתמית אשר מטרתה להאיץ את תהליך החיפוש של ביטויים מסוג זה. התשתית מנצלת מידע אשר נאסף בזמן דחיסת התעבורה. HTTP דחוס לרוב בעזרת אלגוריתם GZIP אשר משתמש בהצבעות-אחורה על מנת לייצג מחרוזות אשר חוזרות על עצמן במידע בעזרת מספר קטן יותר של תווים. האלגוריתם שלנו מבוסס על חישוב המספר המקסימלי של תווים (קודמים) רלוונטים, עבור כל תו, אשר עשויים להוות חלק מזיהוי של תבנית. כאשר אנחנו בוחנים הצבעה-אחורה, רק תווים אלו צריכים להילקח בחשבון ולכן ניתן לדלג על חלקים נרחבים מהמידע ללא חשש לפספוס של זיהוי פוטנציאלי. על ידי כך ניתן לחסוך זמן רב במהלך הסריקה לעומת אלגוריתם נאיבי אשר סורק את כל המידע הפרוס. בנוסף, אנחנו מראים בעבודה זו כי התשתית שלנו עובדת עם מימושים שונים של תשתיות סריקה אשר מבוססים על אוטומטים מסוג NFA או DFA. בשני המקרים התשתית שלנו מספקת שיפור ביצועים של למעלה מ 70%. בנוסף, ניתן להשתמש בתשתית לטובת אפליקציות חשובות נוספות כגון חילוץ מחרוזת הרלוונטית לאחר זיהוי, ועוד.



המרכז הבינתחומי הרצליה

ביה"ס אפי ארזי למדעי המחשב

האצת חיפוש מחרוזות בעזרת ביטויים רגולריים מעל גבי תעבורת HTTP דחוסה

סיכום עבודת גמר המוגשת כמילוי חלק מהדרישות לקראת תואר

מוסמך במסלול מחקרי במדעי המחשב

על ידי עומר כוכבא

העבודה בוצעה בהנחיית פרופ' ענת ברמלר-ברוד"ר ירון קורל

6 בינואר 2016